

XYL'EM

Hydraulic conductance and embolism measurement system

INTRODUCTION

INRA (Institut National de Recherches Agronomiques) is the French institute specialised in research and development in agriculture. The INRA laboratory UMR PIAF is specialised in the study and measurement of xylem conductance and embolism. As studies involving measurements of xylem embolism are becoming more and more frequent and no equipment was available on the market, the INRA research workers designed their own integrated system and asked INSTRUTEC to manufacture and sell it.

INSTRUTEC is the French daughter company of Bronkhorst High-Tech B.V which manufactures the largest variety of thermal mass flow meters and controllers for gases and liquids. Together, INRA and INSTRUTEC have the pleasure to introduce you the XYL'EM system.

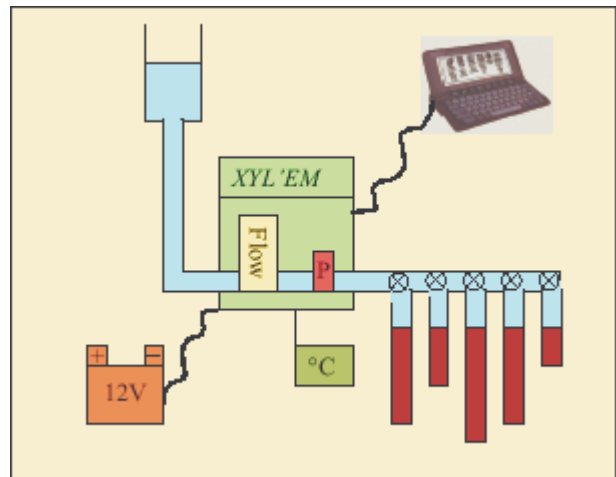

DESCRIPTION

The XYL'EM is a stand alone equipment able to determinate the hydraulic conductance and the embolism rate of vegetal segments. It can be used in laboratory or in the field thanks a rugged suitcase, a 12 Vdc power supply and a temperature compensation. Its LCD display indicates the flow, the pressure and the temperature of the water. As an option, the XY'LEM can be coupled to a PC through an RS 232 interface.

The XYL'EM can be used at low pressure (100 mbg) or at high pressure (HPFM) (3 bars typical, up to 7 bars) as a 1 litre pressurised-tank is integrated into the instrument.

APPLICATIONS

- Xylem hydraulic conductance and embolism measurements in the lab or in the field
- Plant physiology and plant water relations
- Analysis of plant hydraulic architecture
- Evaluation of plant drought resistance
- Evaluation of plant frost resistance
- Impact of xylem pathogens

References to the XY'LEM apparatus :

Cochard et al 2000 Plant Physiol 124:1191-1202

Cochard et al 2002 Plant Physiol 128:282-290

Cochard 2002 Planta 215:456-471

SPECIFICATIONS

Flow measurement:

- Principle: Thermal mass flow measurement
- Measuring range : 0.1... 5 g/h, 0.2... 10 g/h, 0.4... 20g/h, 1... 50 g/h, 2... 100 g/h H₂O (to be specified on the order).
- Accuracy: +/- 1% full scale
- Rangeability : 1 to 50

Low pressure generation and measurement:

- Principle: Water column
- Measuring range : 1 .. 7 kPa typ. (10 kPa max)
- Accuracy: +/- 0,2 kPa

High pressure generation and measurement:

- Principle: Pressurised vessel
- Measuring range : up to 3 bar typ, 7 bar max.
- Accuracy: +/- 1 % full scale



Temperature

- Sensor: Pt100 probe
- Measuring range : 0°C to 50°C
- Accuracy: +/- 0.2 °C

Water supply:

High pressure:

- Vessel capacity: 1 l
- Max vessel pressure: 3 bars, (7 bars possible if filter is removed).

Low pressure:

- Vessel capacity: 100 ml
- Max vessel pressure: 1 meter water high
- Water filtration: 0,2 µm.

Mechanical characteristics

- Suitcase : IP65
- Dimension : 461x347x206 mm
- Weight (empty vessel): 10 kg

Electrical characteristics

- Power supply : 12Vdc
- Consumption : 900mA
- Electrical connection : Din 3 pins

Computer connection (option):

- Analog to digital conversion (15 bits resolution) and RS232 interface for data transfer to a computer.
- XYL'EM software for DOS and windows environments. This software collects the data, calculates the corrections and determines embolism factor.

ORDERING INFORMATIONS:

XYLEM: Stand alone hydraulic conductance measurement system

DATAXYL: RS232 Interface with data processing software and cable

LIQUIFLOW: Spare liquiflow meter to operate with a different flow range

LIQUIFLOW RECAL: Modification of the measuring range on an existing liquiflow

COMPXYL: Portable 7 bar compressor, 12 Vdc power supply for field measurement.

FILTERS: Box of 50 0.2 µm filters

COUPLINGS: Set of 4 couplings to connect 5 to 30 mm samples to luer connectors.

COMPONENTS INCLUDED IN THE SYSTEM:

- 90 - 220V (50-60 Hz)/ 12Vdc 1 A Power supply.
- Pt100 probe
- 5 spare 0.2 µm filters
- Stainless steel to polypropylene luer converters
- 100.ml serynge for water column
- Set of tubes with luer fittings
- 4 channels sample water feeder
- Start up procedure manual
- The Tricks of the trade to measure hydraulic conductance.